



Gold Series

vănEE 2001 HRV

Part no. 45828

114 to 250 CFM (0.3 in. w.g.)

108 to 235 CFM (0.4 in. w.g.)



VB0024

FOR RENOVATION AND CUSTOM BUILT HOUSES

Designed for homeowners seeking the best performance, added value, quality and a longer warranty.

Recognized for its unsurpassed quality and superior craftsmanship, the Gold Series reflects a new level of exceptional performance. It is guaranteed to satisfy the homeowner looking for durability, reliability and performance. The Gold Series: The best of the vănEE experience.

Solid Performances

- Best heat recovery in its category
- Best airflow range in its category
- Exclusive convertible HRV to an ERV (Latent Recovery Core)
- Gold Series blower design makes the unit quieter than ever

Superior Craftsmanship

- External electrical access side panel
- Integrated balancing dampers
- All parts removable in 5 minutes
- Aluminum framed foam filter
- Improved sliding system for core insertion
- Exclusive, deeper one piece condensation tray to prevent water leakage
- No sharp angles on metal parts
- Exclusive, reinforced housing
- Improved defrost damper and damper mechanism, designed to operate during the toughest weather conditions

Tradition of Quality

- Proven technology and mechanical simplicity for heat recovery
- Low motor temperature operation for longer life expectancy
- 5-year warranty
- ENERGY STAR® qualified

Available at:

HEAT RECOVERY VENTILATOR

Controls and options

- Our main control Platinum (no. 40460) allows you to manage your ventilation with a programmable mode. This control also features our fully automated optimizer mode called the Smart mode.
- The following main controls are also available:
 - Deco-Touch digital control no. 40295
 - Basic no. 40210
- One or more of the following optional controls can also be added:
 - Humidity control no. 200694
 - 20/40/60-minute push button no. 03701
 - 60-minute mechanical timer no. 00910
- Integrated furnace interlock relay
- Complete line of registers and diffusers available
- Electric duct heater

No Negative Pressure Defrost

Defrost system ensures that no negative pressure is created by air exhausted to the outside, as the air is recirculated into the house, helping to prevent any backdraft.

| OUTSIDE TEMPERATURE | | DEFROST CYCLE DEFROSTING MIN./ OPERATING MIN. |
|---------------------|----------------|---|
| °C | °F | |
| WARMER THAN -5 | WARMER THAN 23 | No DEFROST |
| -5 TO -30 | 23 TO -22 | 6/32 |
| -30 & COLDER | -22 & COLDER | 6/20 |

Heat Recovery Core

Dimensions: 12" x 12" x 16.75" (30.5 x 30.5 x 42.54 cm)

Exchange surface: 166 ft² (15.44 m²)

Weight: 9.5 lb (4.3 kg)

Type: Crossflow

Material: Polypropylene

Warranty: Lifetime

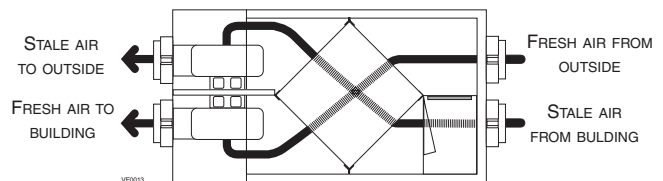

Requirements and Standards

- Complies with the CSA C22.2 no. 113 Standard applicable to ventilators
- Complies with the CSA C444 requirements regulating the installation of Heat Recovery Ventilators
- Technical data was obtained from published results of tests relating to CSA C429 Standards
- HVI certified and ENERGY STAR® qualified

Dimensions: vänEE 2001 HRV

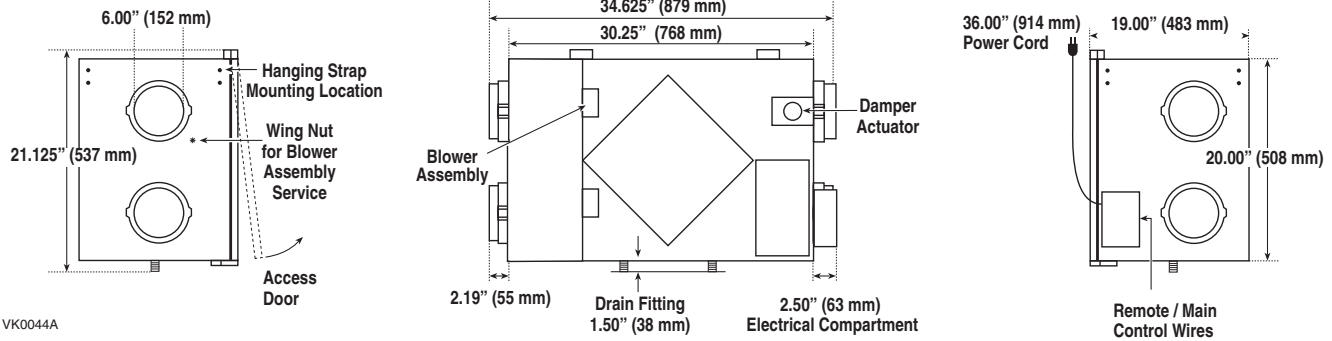

VK0044A

Ventilation Performance

| EXTERNAL STATIC PRESSURE | | NET SUPPLY AIR FLOW | | GROSS AIR FLOW | | | |
|--------------------------|----------|---------------------|-----|----------------|-----|---------|-----|
| | | | | SUPPLY | | EXHAUST | |
| Pa | in. w.g. | l/s | cfm | l/s | cfm | l/s | cfm |
| 50 | 0.2 | 119 | 253 | 125 | 264 | 126 | 268 |
| 75 | 0.3 | 118 | 250 | 124 | 262 | 118 | 251 |
| 75 | 0.4 | 111 | 235 | 116 | 245 | 114 | 241 |
| 100 | 0.5 | 102 | 216 | 106 | 224 | 107 | 226 |
| 125 | 0.6 | 87 | 185 | 91 | 193 | 96 | 204 |
| 150 | 0.7 | 76 | 160 | 79 | 167 | 81 | 172 |
| 175 | 0.8 | 57 | 120 | 59 | 124 | 57 | 121 |

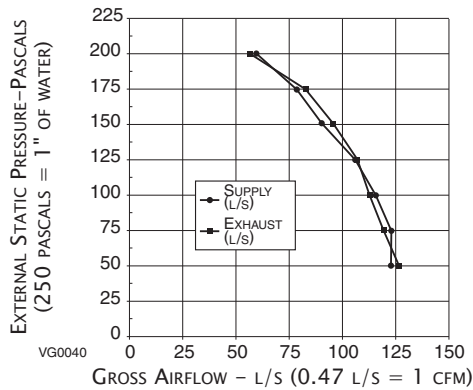

VG0040

Energy Performance

| SUPPLY TEMPERATURE | | NET AIR FLOW | | AVERAGE POWER WATTS | SENSIBLE RECOVERY EFFICIENCY | APPARENT SENSIBLE EFFECTIVENESS | LATENT RECOVERY MOISTURE TRANSFER |
|--------------------|-----|--------------|-----|---------------------|------------------------------|---------------------------------|-----------------------------------|
| °C | °F | L/S | CFM | | | | |
| HEATING | | | | | | | |
| 0 | 32 | 51 | 109 | 92 | 70 | 77 | -0.01 |
| 0 | 32 | 73 | 155 | 128 | 65 | 72 | -0.02 |
| 0 | 32 | 102 | 215 | 191 | 62 | 70 | -0.01 |
| -25 | -13 | 52 | 110 | 104 | 60 | 94 | 0.05 |
| COOLING | | | | | | | |
| 35 | 95 | | | | TOTAL RECOVERY EFFICIENCY | | NOT TESTED |

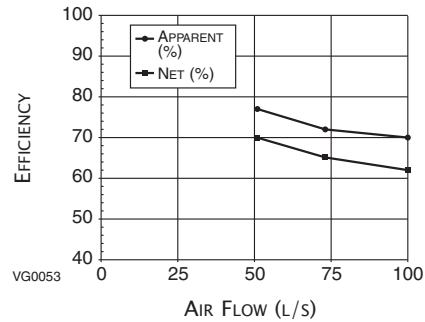

VG0053

Specifications

- Model: 2001 HRV
- Part number: 45828
- Total assembled weight with polypropylene or enthalpic transfert media core: 73 lb (33 kg)
- Supply air duct connections: 6" diameter
- Exhaust air duct connections: 6" diameter
- Drains: 1/2" fittings
- Filters: 30 ppi washable reticulated foam 11.75" x 16.75" x 0.75" (29.85 x 42.55 x 1.9 cm)

- Housing: Pre-painted steel
- Insulation: 1" aluminum foil faced fiberglass
- Mounting: Reinforced rubber straps (or chain) and hardware provided to suspend unit
- Supply & Exhaust blower motors:
 - Bearings: Sleeve bearings
 - Type: PSC

- Fan speed control:
 - Low, increased low, high speed
 - Two speeds available to user
 - Low or increased low speed is selected at the time of installation
- Unit electrical characteristics:
 - Voltage: 120 Volts
 - Power: 202 Watts
 - Current: 1.9 Amperes

NOTE: All specifications are subjected to change to change without notice.

| PROJECT: | REMARKS |
|---------------|---------|
| LOCATION: | |
| MODEL NO.: | |
| QTY.: | |
| SUBMITTED BY: | DATE: |



550 Lemire Blvd., Drummondville, QC, Canada J2C 7W9 - Tel.: 1-800-567-3855 Fax: 1-800-567-1715



www.vanee-ventilation.com

12/03

PRODUCT SHEET NO. 90197